



## CANAPÉ 2 PLACES TREND

## CANAPÉ 3 PLACES TREND



### CARACTÉRISTIQUES TECHNIQUES

Structure du fauteuil, du dossier et des accoudoirs composés d'un châssis en liteaux de bois de sapin de 25 mm d'épaisseur et de panneaux en multicouche de bouleau de 18 mm d'épaisseur et MDF pour séparations de 3 mm d'épaisseur.

Assise dotée de support renforcé à bandes élastiques à portance élevée.

Revêtement tissu.

La structure de base à luge est réalisée en plaque d'acier chromé de 4 mm d'épaisseur.

Rembourrage :

Assise et dossier: composés de polyuréthane expansé (densité de 28 Kg/m<sup>3</sup>) et d'un complexe blanc en fibre thermocollée et velours.

Coussin d'appui et accoudoirs en polyuréthane expansé (densité de 40 Kg/m<sup>3</sup>) revêtus de fibre thermocollée et velours.

*Fabrication italienne.*

### DIMENSIONS

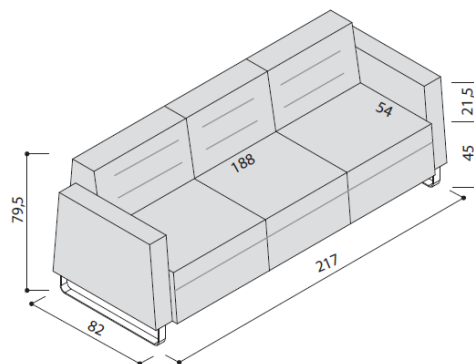
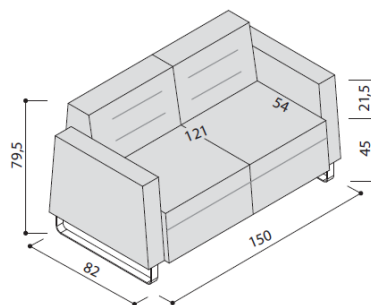

### LIEN PARTENAIRE

<http://www.las.it/>



67 rue André Lardy  
 ZAE La Mare  
 97438 Sainte-Marie



OffitalReunion



0262 976 800



## NUANCIER

### CAT\_A

100% Polypropylene F.R.  
 Poids: 250 gr/m<sup>2</sup>  
 Martindale 50.000 cycles  
 Ignifuge classe 1

POLI

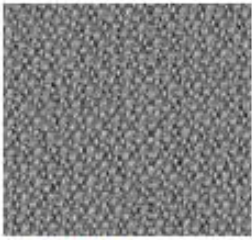

475 - Grigio  
 Grey | Gris



476 - Grigio Melange  
 Melange Grey | Gris Mélange



477 - Nero  
 Black | Noir

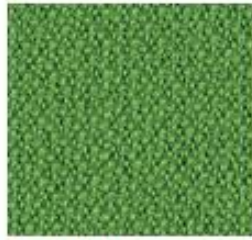

478 - Verde Chiaro  
 Light Green | Vert Clair



479 - Verde  
 Green | Vert

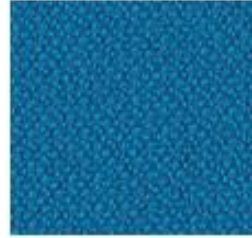

480 - Azzurro  
 Azure | Azur



481 - Blu  
 Blue | Bleu



482 - Arancio  
 Orange | Orange



483 - Rosso  
 Red | Rouge



484 - Bordeaux  
 Bordeaux | Bordeaux

